

# EXAMPLE

Educational Institution «Belarusian State Medical University»

The Faculty of Career Guidance and pre-University Training

End-of-course examination in  
the discipline «Biology» for  
the students of the Faculty  
of Career Guidance and  
Preuniversity Training.



APPROVED  
Head of the Biology Department  
V.V. Davydov  
13.09.2022, protocol #2

Test #01

**I. Find the correct answer for each question. Write the letters of your answers to the table in the answer sheet.**

1. Living organisms consist of: a) cells, b) solts, c) water, d) air, e) crystals.
2. Muscles can: a) contract, b) analyze stimuli of the environment, c) conduct impulse from the brain, d) digest food, e) excrete wastes to the environment.
3. The number of lobes in lungs: a) is same – 1 lobes in each lung, b) is same – 2 lobes in each lung, c) is same – 3 lobes in each lung, d) is not same – 3 lobes the left lung and 2 lobes in the right lung, e) is not same – 2 lobes the left lung and 3 lobes in the right lung.
4. Integumentary system of the body includes: a) iris, lens, choroid, b) pia, dura, arachnoid, c) pancreas, salivary glands, gallbladder, d) ganglions, nerves, e) skin, hair, nails.
5. Organ of Corti is situated in: a) inner ear, b) acoustic meatus, c) middle ear, d) Eustachian tube; e) eardrum.
6. Paramecium caudatum does not have: a) nuclei; b) pigment chlorophyll; c) digestive vacuoles; d) contractile vacuoles; e) cilia.
7. Example of reptiles: a) turtle, b) frog, c) shark, d) dolphin, e) platypus.
8. Insects belong to: a) animals, b) plants, c) bacteria, d) fungi, e) protozoa.
10. Pectoral girdle of reptiles consists of: a) scapulae and clavicles; b) sternum, scapulae and clavicles; c) sternum, coracoids, scapulae and clavicles; d) sternum, coracoids and clavicles; e) coracoids and clavicles.
11. Any cell has: a) cytoplasm, b) flagella, c) cilia, d) cell wall, e) capsule.
12. Organs of sight in reptiles: a) 2 eyes, b) 4 eyes, c) ears, d) skin and tongue, e) brain and spinal cord.
13. Bonds between thymine and adenine are of complementary DNA strands are: a) 2 peptide bonds, b) 2 hydrogen bonds, c) 3 phosphodiester bonds, d) 2 phosphodiester bonds, e) 3 hydrogen bonds.

**II. Fill in the gaps. Write your answers to the table in the answer sheet.**

14. The number of bones in the forearm is ...
15. The miracidium of liver fluke hatches from the ...
16. Spiders weave a ... from spider silk for hunting.

# EXAMPLE

# EXAMPLE

## III. Write the answers for the questions to the table in the answer sheet.

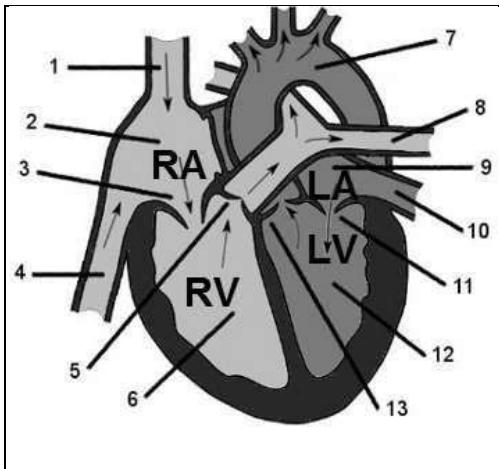
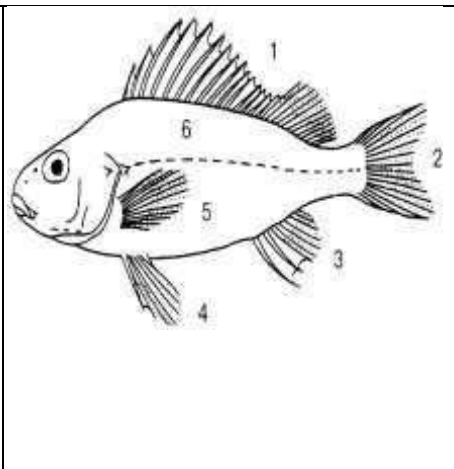
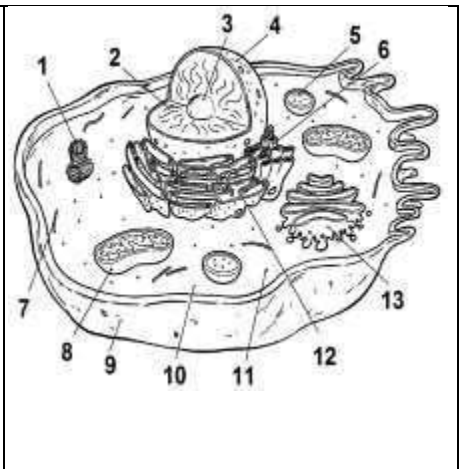
		
<p>17. What is indicated with "9" in this diagram?</p>	<p>18. What is indicated with "3" in this diagram?</p>	<p>19. What is indicated with "3" in this diagram?</p>

## IV. Solve the problems and write the answers and the solutions to the answer sheet.

20. There is a double-stranded DNA fragment which contains 41% adenine nucleotides. What is the percentage of guanine nucleotides in this DNA fragment?

21. Brown eye color in humans is determined by the dominant allele (B) of certain gene. The recessive allele of this gene (b) is responsible for blue color of eyes. The dominant allele of another gene (C) causes nearsightedness. Its recessive allele (c) provides normal sight. A man who is heterozygous for both the genes married a recessive homozygous woman. What percentage of children with father's genotype could be expected in children (F<sub>1</sub>) of this family?

22. What types of gametes could be formed by a female fruit fly (*Drosophila melanogaster*)  $\overline{AB}$  with such genotype? What is their percentage? The distance between the genes is 33 centimorgans.  $\underline{ab}$

23. The recessive allele of an X-linked gene causes hemophilia in humans. A woman-carrier of hemophilia married a healthy man. What is the chance that daughters born in this family are carriers of hemophilia?

24. What is the inheritance type in this case? What is the genotype of the person I-1?

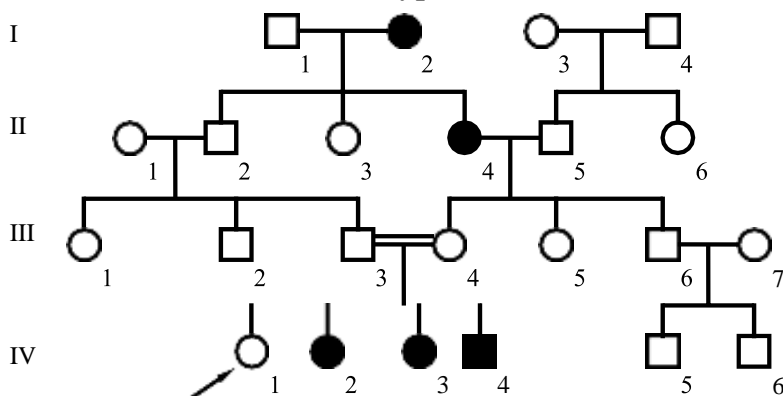

## V. Write the detailed answer for the question.

25. Describe the properties of living matter.

Compiler



V.V. Grigorovich

# EXAMPLE

# EXAMPLE

Educational Institution «Belarusian State Medical University»

The Faculty of Career Guidance and pre-University Training

End-of-course examination in  
the discipline «Biology» for  
the students of the Faculty  
of Career Guidance and  
Preuniversity Training.



APPROVED  
Head of the Biology Department  
V.V. Davydov  
13.09.2022, protocol #2

Test #02

## I. Find the correct answer for each question. Write the letters of your answers to the table in the answer sheet.

1. Digestive system: a) processes food, b) pumps air, c) provides excretion of most of nitrogen-containing metabolic wastes, d) pumps blood, e) provides locomotion.
2. Smooth muscles form muscular layers of: a) wall of the stomach, blood vessels, heart; b) wall of blood vessels, heart; c) wall of the heart; d) wall of the stomach; e) wall of bronchi and lungs.
3. Organs of the circulatory system are: a) heart and vessels, b) skin with derivatives, c) larynx and bronchi, d) esophagus and duodenum, e) all the answers are wrong.
4. Anatomically, the nervous system is divided into: a) sympathetic and vegetative; b) sympathetic and parasympathetic; c) autonomous and vegetative; d) central and autonomous; e) central and peripheral.
5. Bones are structural components of: a) skeleton, b) brain and spinal cord, c) heart and vessels, d) urinary system, e) respiratory tract.
6. Amoeba consists of: a) one cell, b) forty to fifty cells, c)  $10^6$  cells, d)  $10^{12}$  cells, e) all the answers are wrong.
7. Conditions required for development of *Ascaris* eggs are: a) soil, temperature  $25^{\circ}\text{C}$ , humidity; b) being in the human body; c) water, temperature  $15^{\circ}\text{C}$ ; d) water, temperature  $15-25^{\circ}\text{C}$ ; e) dry soil, temperature  $10^{\circ}\text{C}$ .
8. Sight organs of arachnids are: a) simple eyes on the cephalothorax; b) compound eyes on the cephalothorax; c) simple eyes on the abdomen; d) compound and simple eyes on the head; e) compound eyes on the abdomen.
9. Bacilli is a type of: a) bacteria, b) mammals, c) birds, d) reptiles, e) worms.
10. Animals that do not lay eggs are: a) human, b) birds, c) lizards, d) turtles, e) all the answers are wrong.
11. Nucleic acids contain: a) fructose and ribose, b) ribose and deoxyribose, c) glucose and fructose, d) glucose and deoxyribose, e) fructose and deoxyribose.
12. A metacentric chromosome is a chromosome which has: a) arms of the same length, b) no centromere, c) one very long arm and other very short arm, d) only one arm, e) satellite of the short arm.
13. Science about life is: a) Biology, b) Physics, c) Mathematics, d) Chemistry, e) Astronomy

## II. Fill in the gaps. Write your answers to the table in the answer sheet.

14. The molecule consisting of nucleotides and carrying genetic information is abbreviated as ...
15. The upper extremity of human is...
16. Chemical elements such as copper contained in human body in low amounts are called ...

# EXAMPLE

# EXAMPLE

### III. Write the answers for the questions to the table in the answer sheet.

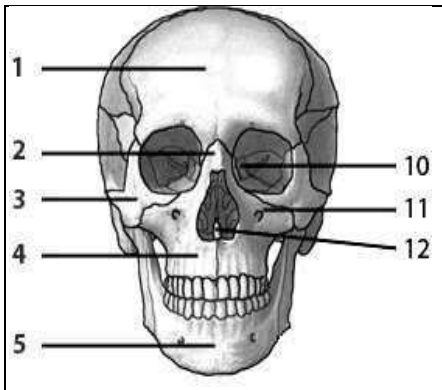
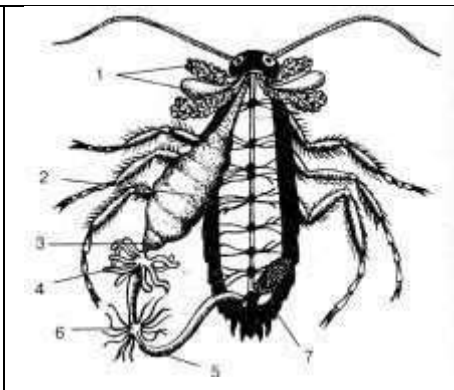
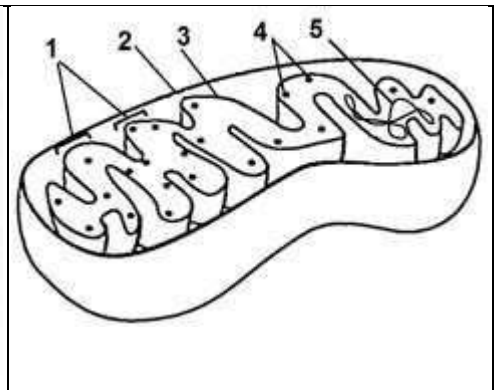
		
<p>17. What is indicated with "1" in this diagram?</p>	<p>18. What is indicated with "6" in this diagram?</p>	<p>19. What is indicated with "1" in this diagram?</p>

### IV. Solve the problems and write the answers and the solutions to the answer sheet.

20. There is a double-stranded DNA fragment which contains 9% guanine nucleotides. What is the percentage of adenine nucleotides in this DNA fragment?

21. Brown eye color in humans is determined by the dominant allele (B) of certain gene. The recessive allele of this gene (b) is responsible for blue color of eyes. The dominant allele of another gene (C) causes nearsightedness. Its recessive allele (c) provides normal sight. A man who is heterozygous for both the genes married a recessive homozygous woman. What percentage of children with mother's genotype could be expected in children (F<sub>1</sub>) of this family?

22. What types of gametes could be formed by a female fruit fly (*Drosophila melanogaster*) with such genotype? What is their percentage? The distance between the genes  $\overline{AB}$  is 10 centimorgans.  $ab$

23. The recessive allele of an X-linked gene causes hemophilia in humans. A woman-carrier of hemophilia married a healthy man. What is the chance that daughters born in this family are phenotypically healthy?

24. What is the inheritance type in this case? What is the genotype of the person I-1?

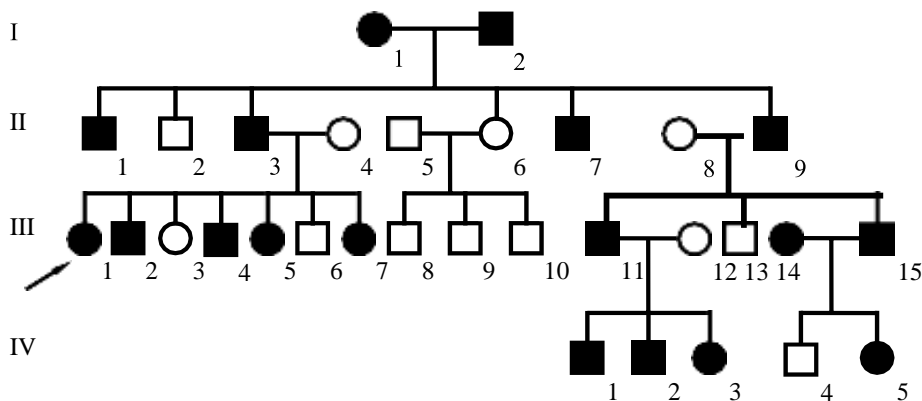

### V. Write the detailed answer for the question.

25. Describe the organelles of cell's anabolic system.

Compiler



V.V. Grigorovich

# EXAMPLE